

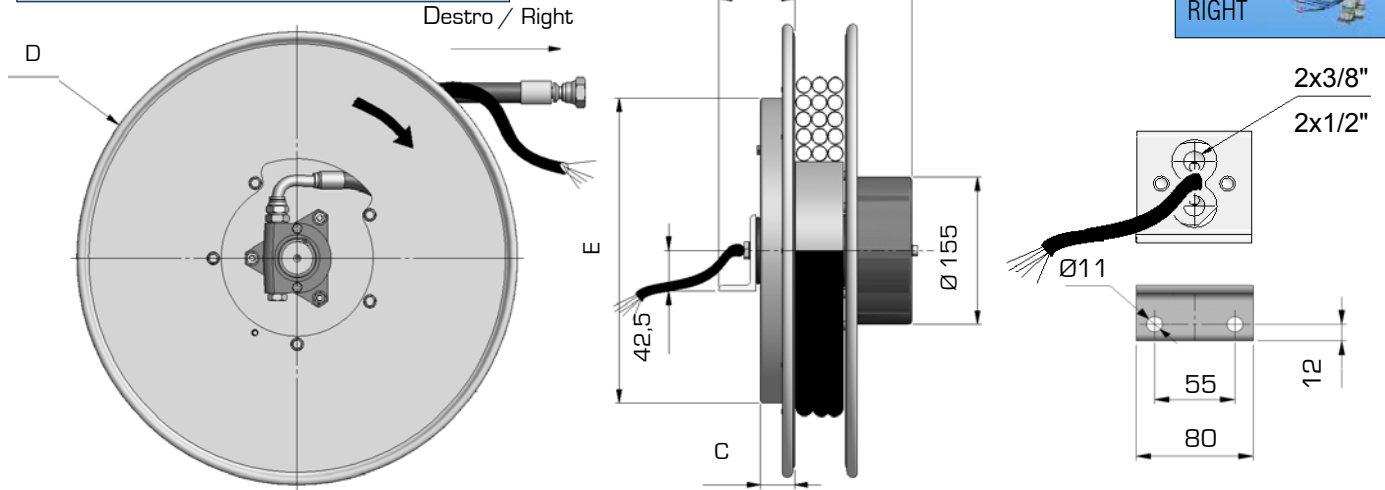
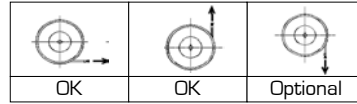

**DESTRO
RIGHT**
141.1
**MAX
40 l/min**
**W.P.
300 bar**
**75V
5A**

 AGD 470 = MODELLO DESTRO / RIGHT MODEL
 AGS 470 = MODELLO SINISTRO / LEFT MODEL
 Es. ORD: AGD 470.10.R7/E4

Modello destro Right model	Cavi Wires N°	A	B	C	D	E	CON TUBO - WITH HOSE			
							1/4" - R7	5/16" - R7	3/8" - R7	3/8" - R8
		mm					Y=06	Y=08	Y=10	Y=10
							X=R7	X=R7	X=R7	X=R8
							m	m	m	m
AGD420.Y.X/E2	2	205								
AGD420.Y.X/E3	3	217								
AGD420.Y.X/E4	4	225	82	37	420	322	8,6	8,0	6,7	6,7
AGD420.Y.X/E6	6	245								
AGD420.Y.X/E8	8	245								
AGD420.Y.X/E12	12	280								
AGD470.Y.X/E2	2	205								
AGD470.Y.X/E3	3	217								
AGD470.Y.X/E4	4	225	82	37	478	322	11,5	10,0	9,5	9,5
AGD470.Y.X/E6	6	245								
AGD470.Y.X/E8	8	245								
AGD470.Y.X/E12	12	280								
AGD520.Y.X/E2	2	205								
AGD520.Y.X/E3	3	217								
AGD520.Y.X/E4	4	225	82	37	520	422	14,5	12,5	11,2	11,2
AGD520.Y.X/E6	6	245								
AGD520.Y.X/E8	8	245								
AGD520.Y.X/E12	12	280								
AGD570.Y.X/E2	2	205								
AGD570.Y.X/E3	3	217								
AGD570.Y.X/E4	4	225	92	47	570	422	17,5	15,5	13,5	13,5
AGD570.Y.X/E6	6	245								
AGD570.Y.X/E8	8	245								
AGD570.Y.X/E12	12	280								
AGD600.Y.X/E2	2	205								
AGD600.Y.X/E3	3	217								
AGD600.Y.X/E4	4	225	92	47	620	422	21	17	16	16
AGD600.Y.X/E6	6	245								
AGD600.Y.X/E8	8	245								
AGD600.Y.X/E12	12	280								
AGD650.Y.X/E2	2	205								
AGD650.Y.X/E3	3	217								
AGD650.Y.X/E4	4	225	92	47	650	422	22,5	19,5	17,5	17,5
AGD650.Y.X/E6	6	245								
AGD650.Y.X/E8	8	245								
AGD650.Y.X/E12	12	280								
AGD700.Y.X/E2	2	205								
AGD700.Y.X/E3	3	217								
AGD700.Y.X/E4	4	225	102	57	720	532	27	22	20	20
AGD700.Y.X/E6	6	245								
AGD700.Y.X/E8	8	245								
AGD700.Y.X/E12	12	280								